

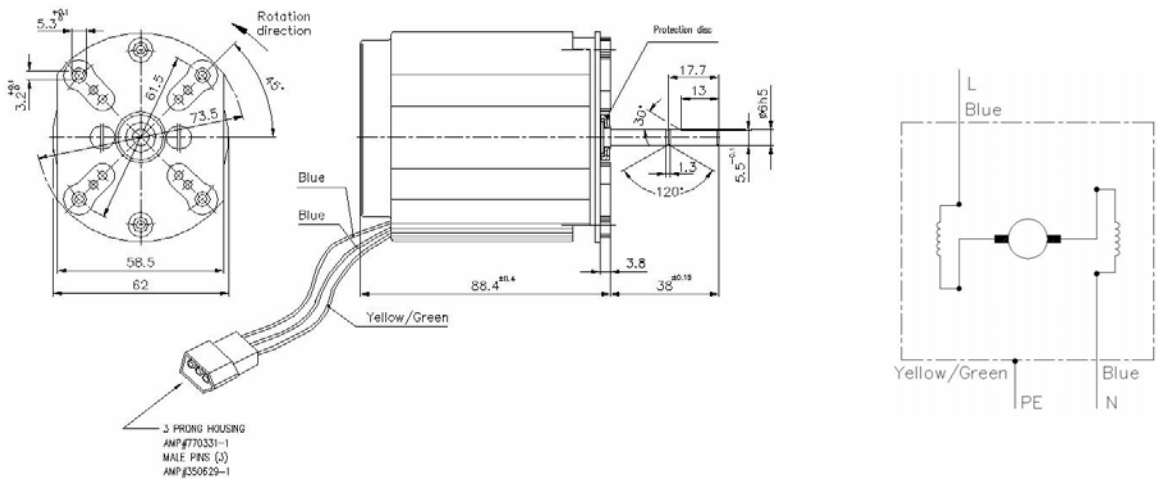

- Protection class: I
- Insulation class: F
- Motor shaft: AISI 303 Stainless steel.
- Thermal protector: 100°C on/off
- Cables: 20AWG 105°C 300V UL approved
- Bearings: Sinter Bronze.

Universal Motor (BM72B 972.10.002)



MOTOR TYPE	MOTOR CODE	TEST VOLT. (V)	TEST FREQ. (Hz)	MOTOR PERFORMANCE VALUES													
				At No Load		At Stall		At Maximum Efficiency				At Maximum Power					
				Speed (RPM)	Cur. (Amp)	Torque (Ncm)	Cur. (Amp)	Torque (Ncm)	Speed (RPM)	Cur. (Amp)	Eff. (%)	Pout (W)	Torque (Ncm)	Speed (RPM)	Cur. (Amp)	Eff. (%)	Pout (W)
BM72B	972.10.002	120	50	17168	0.349	13.36	1.454	3.88	9091	0.699	48.92	36.98	7.46	5747	1.048	42.01	44.87

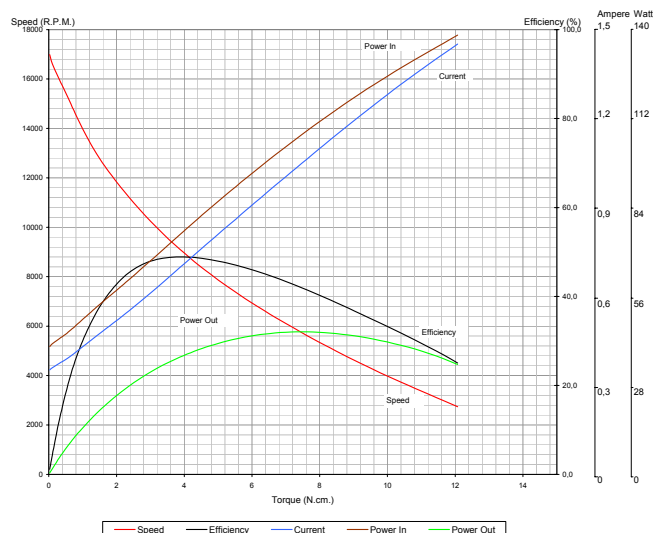

Remarks:

- Documents here includes only reference values. BALKAN MOTOR A.Ş. has the right to revise them without any prior information.
- BALKAN MOTOR A.Ş. could modify all its products according to customer requirements.

BALKAN MOTOR SANAYİ VE TİCARET A.Ş.

Yenibosna Sanayi Caddesi No:21 34530 Bahçelievler/İstanbul/TURKEY

Tel: +90 (212) 551 01 00 (7 Lines) Fax: +90 (212) 551 31 67 www.balkanmotor.com

e-mail: balkan@balkanmotor.com



Quality management system
ISO 9001

- Customer focus
- Customer satisfaction
- Continuous improvement
- System/process effectiveness

ID 15 100 53007

www.tuv-thuringen.de