

- Protection class: I
- Insulation class: F.
- Motor shaft: Ck45 heat treatment on supports
- RFI suppressor: 22 μ H 1A choke coil
- Cables: H03VV-F 0.50mm² VDE approved
- Bearings: Sinter Bronze.

Universal Motor (BM74A 974.10.001)

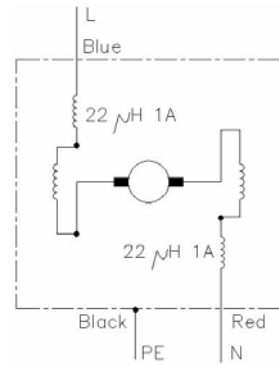

MOTOR TYPE	MOTOR CODE	TEST VOLT. (V)	TEST FREQ. (Hz)	MOTOR PERFORMANCE VALUES													
				At No Load		At Stall		At Maximum Efficiency				At Maximum Power					
				Speed (RPM)	Cur. (Amp)	Torque (Ncm)	Cur. (Amp)	Torque (Ncm)	Speed (RPM)	Cur. (Amp)	Eff. (%)	Pout (W)	Torque (Ncm)	Speed (RPM)	Cur. (Amp)	Eff. (%)	Pout (W)
BM74A	974.10.001	230	50	17124	0.25	25.83	1.073	6.72	8104	0.499	51.34	57.06	16.48	4343	0.853	40.64	74.95

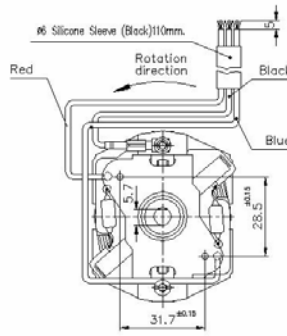
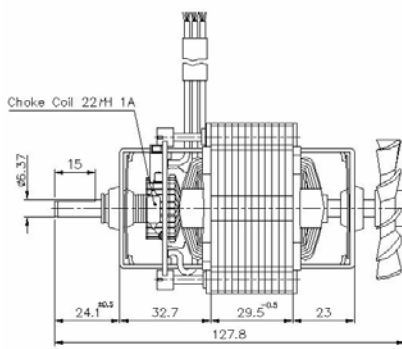
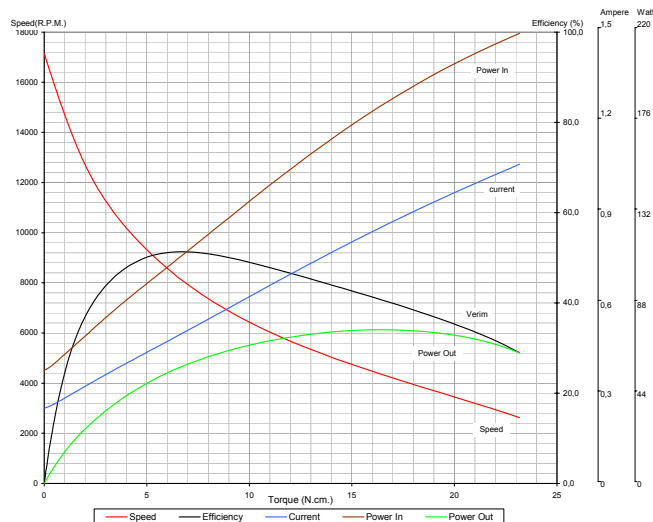

Remarks:

- Documents here includes only reference values. BALKAN MOTOR A.Ş. has the right to revise them without any prior information.
- BALKAN MOTOR A.Ş. could modify all its products according to customer requirements.

BALKAN MOTOR SANAYİ VE TİCARET A.Ş.

Yeni bosna Sanayi Caddesi No:21 34530 Bahçelievler/Istanbul/TURKEY

Tel:+90 (212)551 01 00 (7 Lines) Fax: +90 (212) 551 31 67 www.balkanmotor.com e-mail: balkan@balkanmotor.com



Quality management system ISO 9001

- Customer focus
- Customer satisfaction
- Continuous improvement
- System/process effectiveness

ID 15 100 53007

www.tue-hueingen.de