

Universal Motor (BM63Z 963.94.110)

- Motor shaft: Ck45 20-22HRC.
- Mixer shaft: AISI 303
- Insulation Class: F
- Bearings: Front;608 ZZ Ball bearing
Rear;608 ZZ Ball bearing

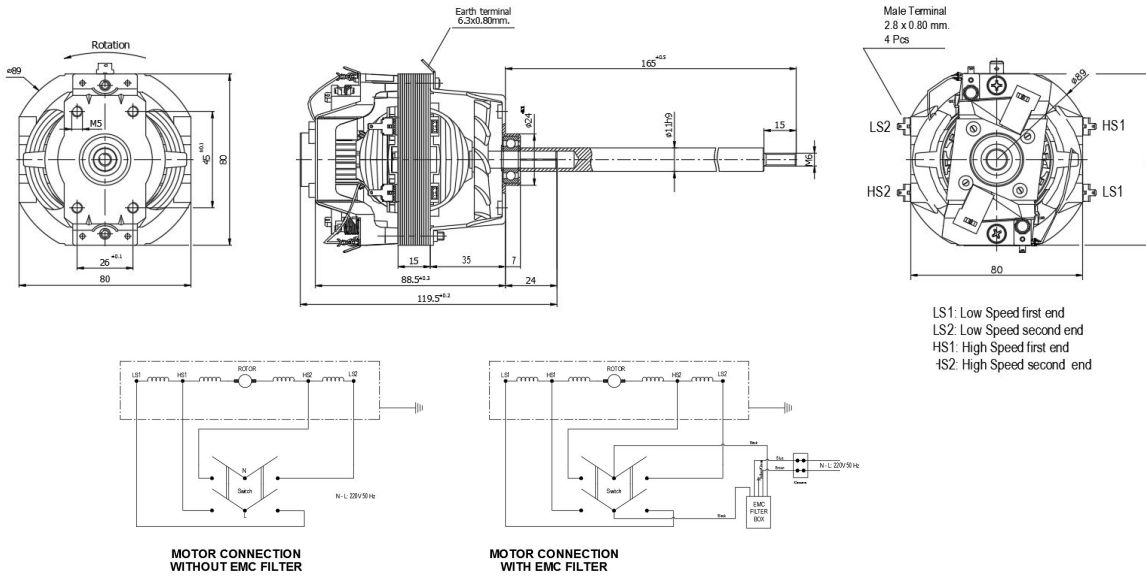

MOTOR TYPE	MOTOR CODE	TEST VOLT. (V)	TEST FREQ. (Hz)	SPEED STEP	MOTOR PERFORMANCE VALUES													
					At No Load		At Stall		At Maximum Efficiency				At Maximum Power					
					Speed (RPM)	Cur. (Amp)	Torque (Ncm)	Cur. (Amp)	Torque (Ncm)	Speed (RPM)	Cur. (Amp)	Eff (%)	Pout (W)	Torque (Ncm)	Speed (RPM)	Cur. (Amp)	Eff (%)	Pout (W)
BM63Z	963.94.110	220	50	1	12871	0.408	10.71	0.967	4.87	6817	0.67	29.61	34.75	5.87	5811	0.723	28.79	35.71
				2	15825	0.52	31.28	2.066	8.2	9715	0.912	44.33	83.46	16.57	5943	1.361	37.9	103.13

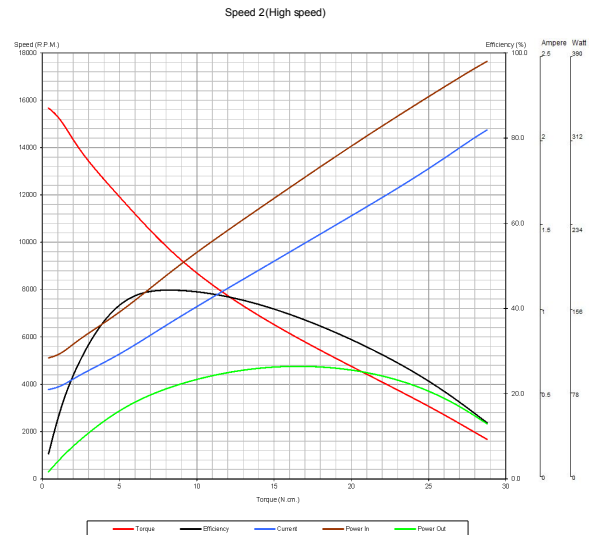
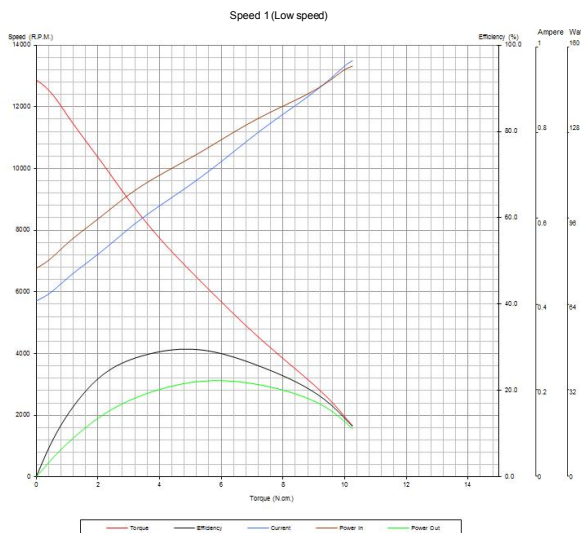

Dipnot:

- Yukarıdaki teknik değerler sadece bilgi amaçlı verilmiştir. BALKAN MOTOR A.Ş. bu değerler üzerinde değişiklik yapmaktadır.
- BALKAN MOTOR A.Ş. müşteri talepleri doğrultusunda ürün üzerinde istenilen değişiklik ve iyileştirmeleri yerine getirebilir.

BALKAN MOTOR SANAYİ VE TİCARET A.Ş.

Yenibosna Sanayi Caddesi No:21 34530 Bahçelievler/İstanbul/TÜRKİYE

Tel:+90 (212)551 01 00 (7 Lines) Fax: +90 (212) 551 31 67 www.balkanmotor.com

e-mail: balkan@balkanmotor.com



Quality management system
ISO 9001

- Customer focus
- Customer satisfaction
- Continuous improvement
- System/process effectiveness

ID 15 100 53007

