

**BALKAN  
MOTOR**  
SANAYİ VE TİCARET A.Ş.  
Since 1953

- Motor shaft: Ck45 20-22HRC.
- Insulation Class: F
- Bearings: Front;608 ZZ Ball bearing  
Rear; Sinter Bronze.

### Universal Motor (BM63A 963.94.001)

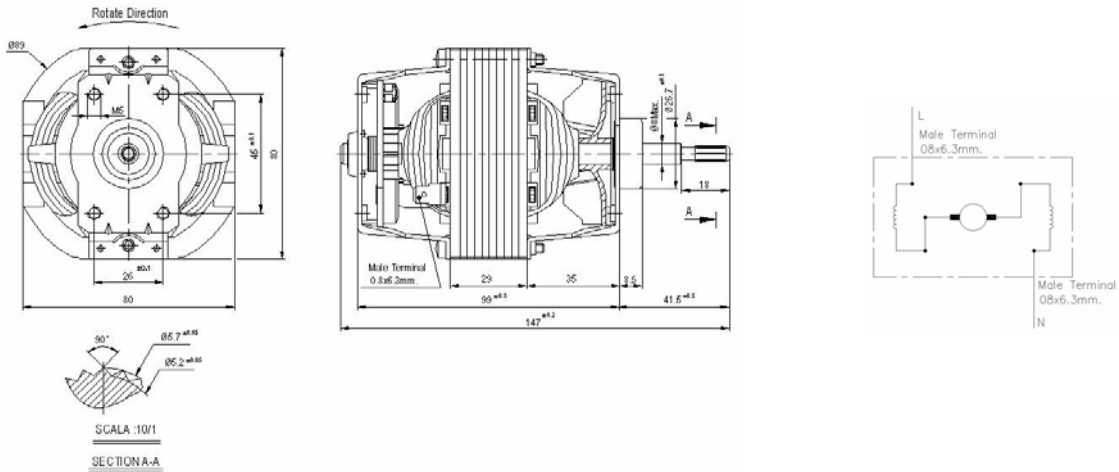

MOTOR TYPE	MOTOR CODE	NOM. VOLT. (V)	FREQ. (Hz)	MOTOR PERFORMANCE VALUES													
				At No Load			At Stall		At Maximum Efficiency				At Maximum Power				
				Speed (RPM)	Cur. (Amp)	Torque (Ncm)	Cur. (Amp)	Torque (Ncm)	Speed (RPM)	Cur. (Amp)	Eff. (%)	Pout (W)	Torque (Ncm)	Speed (RPM)	Cur. (Amp)	Eff. (%)	Pout (W)
BM63A	963.94.001	230	50	17160	0.829	133.76	5.983	26.02	9502	2.132	56.96	285.97	78.72	4859	4.798	43.44	400.63

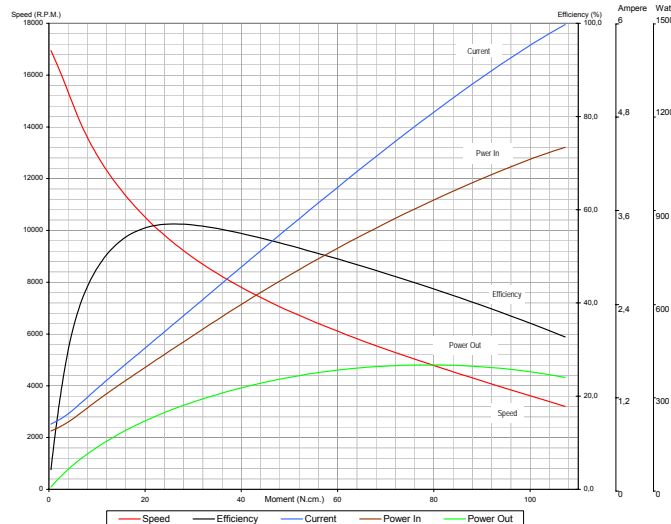

**Remarks:**

- Documents here includes only reference values. BALKAN MOTOR A.Ş. has the right to revise them without any prior information.
- BALKAN MOTOR A.Ş. could modify all its products according to customer requirements.

**BALKAN MOTOR SANAYİ VE TİCARET A.Ş.**

Yenişosna Sanayi Caddesi No:21 34530 Bahçelievler/İstanbul/TÜRKİYE

Tel:+90 (212)551 01 00 (7 Lines) Fax: +90 (212) 551 31 67 www.balkanmotor.com e-mail: balkan@balkanmotor.com



Quality management system  
ISO 9001

- Customer focus
- Customer satisfaction
- Continuous improvement
- System/process effectiveness

ID 15 100 53007

www.tuv-rheinland.com