

- Protection class: 0
- Insulation class: F
- Motor shaft: Ck 45.
- Thermal Protector: Thermal Fuse 104°C cut off
- Cables: H05V-K 0.75mm<sup>2</sup> VDE approved
- Bearings: Sinter Bronze.

### Universal Motor 230V (BM64W964.94.020)

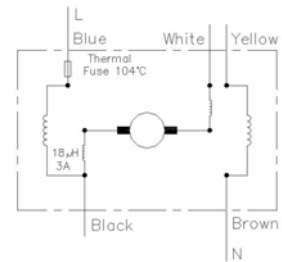

MOTOR TYPE	MOTOR CODE	TEST VOLT. (V)	TEST FREQ. (Hz)	MOTOR PERFORMANCE VALUES													
				At No Load			At Stall			At Maximum Efficiency			At Maximum Power				
				Speed (RPM)	Cur. (Amp)	Torque (Nm)	Cur. (Amp)	Torque (Nm)	Speed (RPM)	Cur. (Amp)	Eff. (%)	Pout (W)	Torque (Nm)	Speed (RPM)	Cur. (Amp)	Eff. (%)	Pout (W)
BM64W	964.94.020	230	50	19822	0.651	78.9	4.772	17.06	10774	1.795	50.21	192.5	46.31	5755	3.564	39.04	279.09

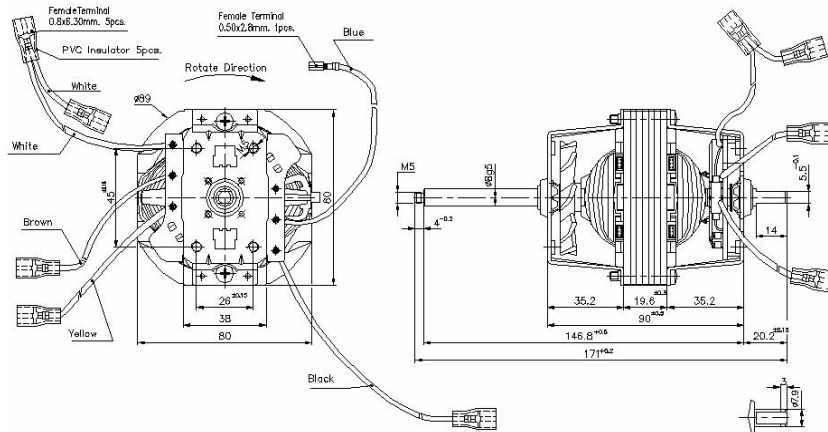
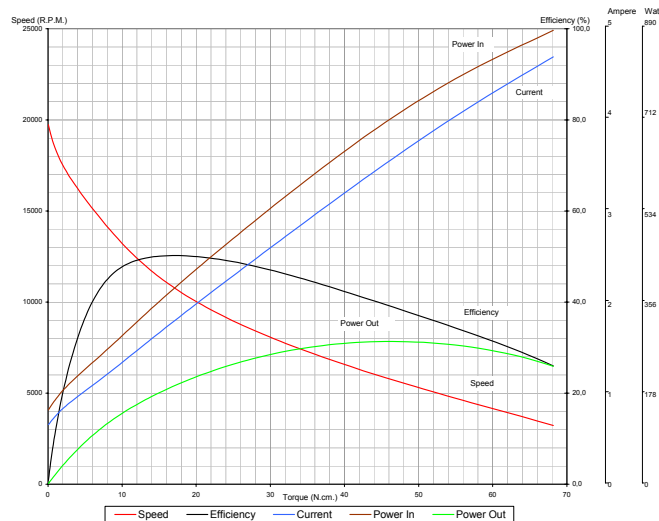

#### Remarks:

- Documents here includes only reference values. BALKAN MOTOR A.Ş. has the right to revise them without any prior information.
- BALKAN MOTOR A.Ş. could modify all its products according to customer requirements.

#### BALKAN MOTOR SANAYİ VE TİCARET A.Ş.

Yenibosna Sanayi Caddesi No:21 34530 Bahçelievler/İstanbul/TÜRKİYE

Tel:+90 (212)551 01 00 (7 Lines) Fax: +90 (212) 551 31 67 www.balkanmotor.com

e-mail: balkan@balkanmotor.com



Quality management system  
ISO 9001

- Customer focus
- Customer satisfaction
- Continuous improvement
- System/process effectiveness

ID 15 100 53007

www.tuv-thuenen.de